

# GEARex® FH and DH All-steel gear coupling

Large shaft distance dimension, high power density

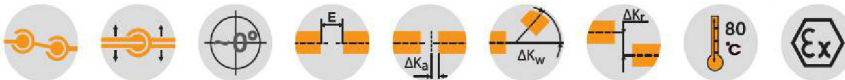

For legend of pictogram please refer to flapper on the cover



Dimensions																	
Size	Torque [Nm]		Pilot bore	Max. finish bore	Dimensions [mm]							Dowel screw (10.9)			Grease feeding [dm <sup>3</sup> ] <sup>2)</sup>		
	TKN	TKN (42CrMo4)		d <sub>1</sub> ; d <sub>2</sub>	l <sub>1</sub> ; l <sub>2</sub>	Lengthened hub max. l <sub>1</sub> ; l <sub>2</sub>	D	DA1 <sup>3)</sup>	DA2 <sup>3)</sup>	LH	EH	F <sup>1)</sup>	d <sub>3</sub> <sup>1)</sup>	z		M	T <sub>A</sub> [Nm]
10	930	1580	26	50	43	105	67	111	84			74	52	6	M6	15	0,02
15	2000	3300	26	64	50	115	87	152	107			84	68	8	M8	36	0,04
20	3500	6300	31	80	62	130	108	178	130			104	85	6	M10	72	0,08
25	6500	11000	38	98	76	150	130	213	158			123	110	6	M12	125	0,12
30	10000	17400	44,5	112	90	170	153	240	182			148	130	8	M12	125	0,18
35	17000	28900	46	133	105	185	180	280	214			172	150	8	M14	200	0,22
40	28500	48500	52	158	120	215	214	318	250			192	175	8	M14	200	0,35
45	37000	62000	80	172	135	245	233	347	274			216	190	10	M14	200	0,45
50	51000	86000	80	192	150	295	260	390	309			241	220	8	M18	430	0,70
55	65000	110000	90	210	175	300	283	425,5	334			275	250	14	M18	430	0,90
60	85000	145000	100	232	190	305	312	457	365,5			316	265	14	M18	430	1,15
70	135000	240000	100	276	220	310	371	527	425			360	300	16	M20	610	1,50
80	175000	300000	140	300	280	-	394	545	475			340	310	18	M20	610	2,50
85	225000	380000	160	325	292	-	430	585	515			352	330	20	M20	610	3,00
90	290000	500000	180	350	305	-	464	640	560			365	360	20	M24	1000	4,00
100	380000	650000	220	390	330	-	512	690	612			390	400	24	M24	1000	5,00
110	480000	820000	220	420	350	-	560	765	665			410	420	20	M30	1700	6,00
120	620000	1050000	260	450	420	-	608	825	720			480	470	24	M30	1700	7,50
130	-	1450000	300	500	440	-	684	950	805			520	520	20	M36	2800	9,00
140	-	1950000	380	550	460	-	750	1020	875			570	590	24	M36	2800	12,00
150	-	2750000	460	630	520	-	850	1140	975			630	670	30	M36	2800	15,00

■ = Standard

<sup>1)</sup> Space required to align the coupling or replace the sealing ring

<sup>2)</sup> Grease feeding for each coupling half

<sup>3)</sup> For dimension type F see page 100. For type D see page 102.

Ordering example:	GEARex® FH 10	d <sub>1</sub> Ø50	d <sub>2</sub> Ø50	250
	Size and type of coupling	Finish bore with keyway to DIN 6885 sheet 1	Finish bore with keyway to DIN 6885 sheet 1	Shaft distance dimension EH

Components

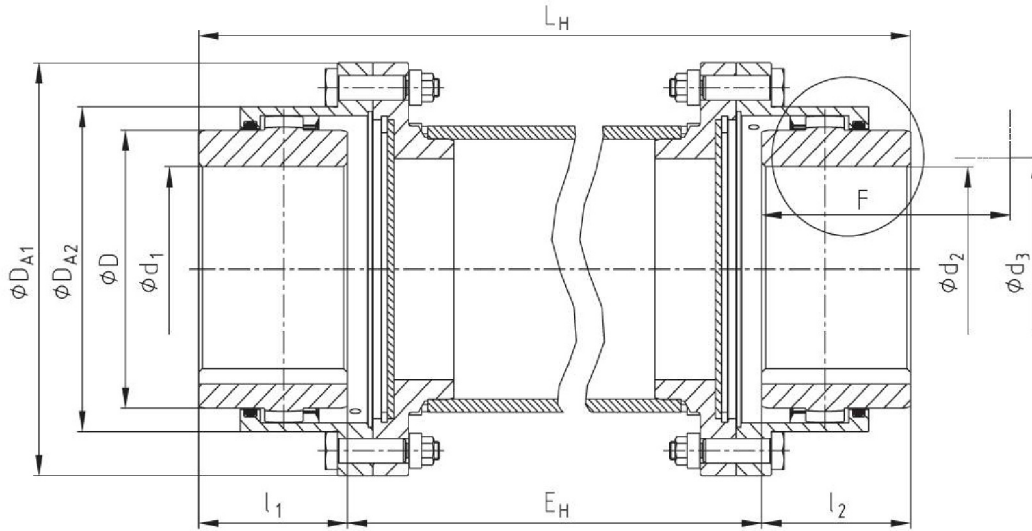

BoWex®

Types

Type FH

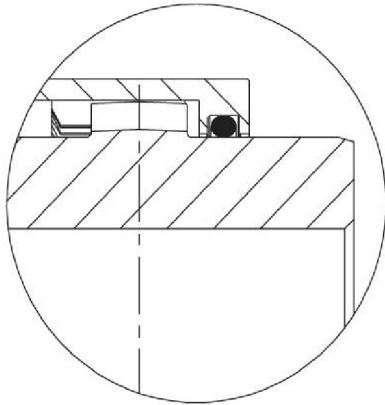

Type DH

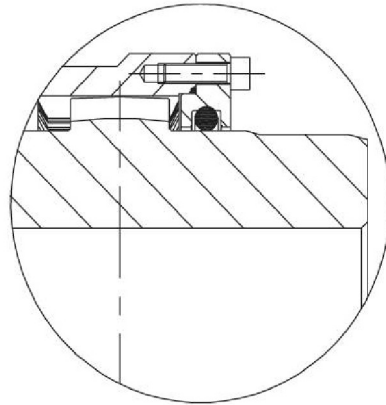

GEARex®